

Infrared Driver

Description

The U426B is an IR-driver-IC for IR data communication. The circuit contains a programmable constant current source (DRV) to drive the IRED. The current is programmed by an external resistor (R_S). With the

internal comparator (COMP) an external voltage can be monitored. The low power standby mode, controlled by means of the WAKE input, makes the circuit well suited for battery powered systems.

Features

- Programmable constant current 200 mA to 1.2 A
- Signal frequency up to 500 kHz
- Low power standby mode
- Internal voltage comparator
- Wide voltage range 2.4 to 12 V

Applications

- Keyless entry systems
- Remote control
- Wireless data communication

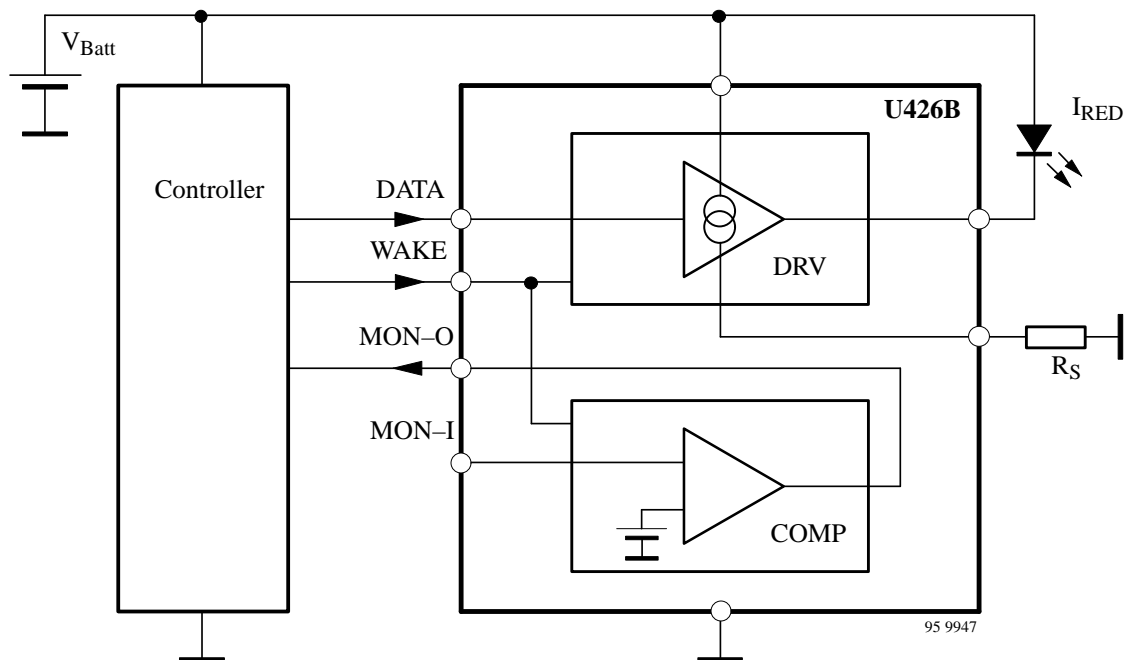
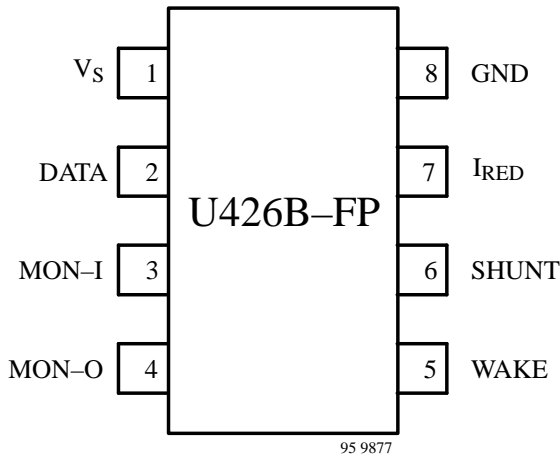

Figure 1.

U426B

Pin Description



Pin	Symbol	Function
1	V_S	Supply voltage
8	GND	Circuit ground
2	DATA	Data input for switching the IRED output current on and off
7	IRED	IR-LED output, when the data input is high this output supplies the IR-LED with the constant current
6	SHUNT	The resistor at this pin adjusts the IRED output current
3	MON-I	Voltage monitor input of the internal comparator
4	MON-O	Voltage monitor output. This open collector output is active when the voltage at MON-I is below the internal reference $V_3 = 525 \text{ mV typ.}$
5	WAKE	WAKE input. When LOW the circuit is in standby mode. A high level activates the circuit

Block Diagram

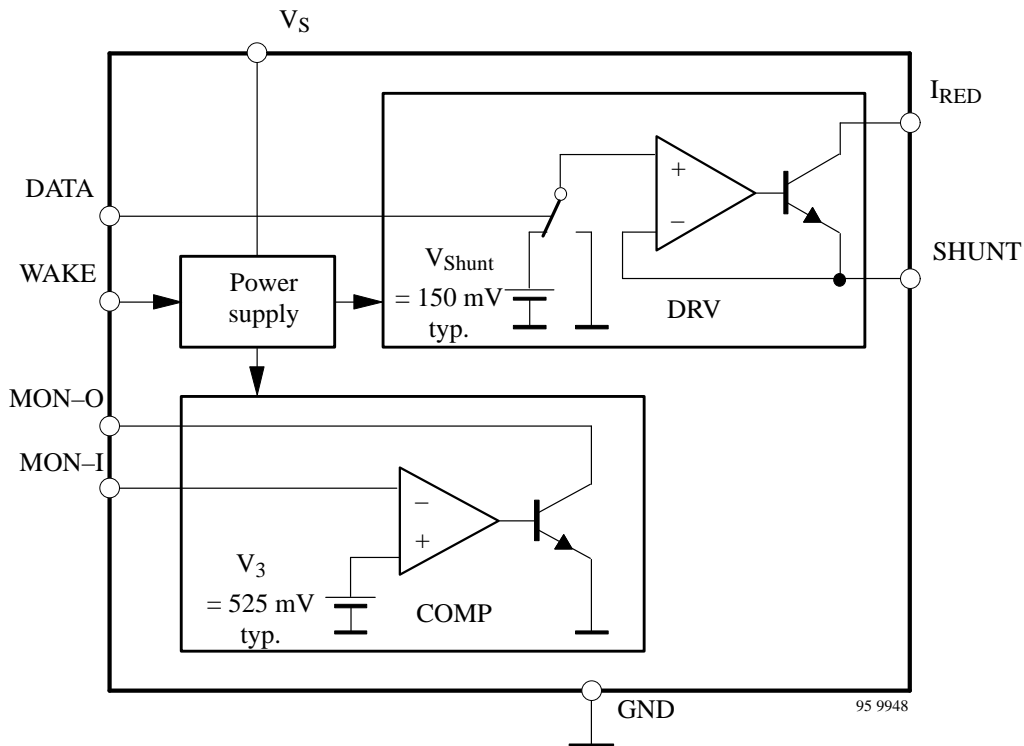

COMP Monitoring comparator
 DRV IRED constant current driver

Figure 2.

Constant Current Driver (DRV)

The constant current driver converts the incoming data pulses into adequate constant current pulses. A high level applied to the data-input causes a constant current flow through the IR-diode connected to the IRED output. This current can be programmed via the external resistor (R_S). To calculate the output current, use the following formula:

$$I_{RED} = 150 \frac{mV}{R_S}$$

Power Supply

The power supply circuit generates the internal supply voltage from an external voltage ($V_S = 2.4$ to 12 V). The V_S -pin is protected by an internal suppressor diode

against voltages above 13 V. The internal supply voltage can be switched on/off with a high/low-level at the WAKE input. Setting WAKE to low level switches the circuit from busy to standby mode, which results in a very low, current consumption ($2 \mu A$). Every change between busy and standby mode needs a latency up to 1 ms. Data transmission and voltage monitoring only takes place while WAKE remains high.

Monitoring Comparator (COMP)

The monitoring comparator compares the voltage at pin MON-I to an internal reference voltage of $V_3 = 525$ mV typ. The open collector output transistor is active, if the voltage at pin MON-I falls below the internal threshold voltage. The comparator can be used to monitor the power supply battery.

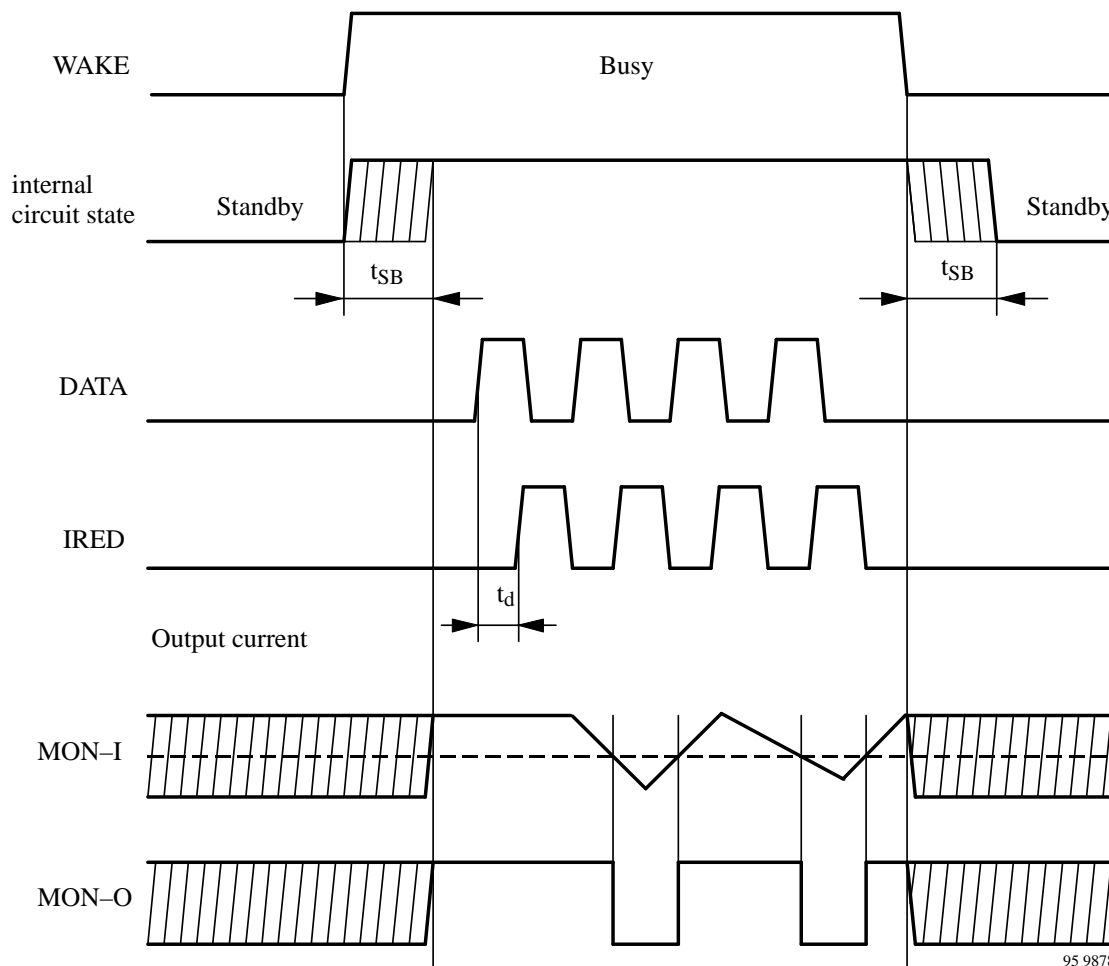

Figure 3. Timing diagram

Absolute Maximum Ratings

Parameters	Symbol	Value	Unit
Supply voltage Pin 1	V_S	13.4	V
Supply current $t < 10 \mu s$	I_S i_s	40 150	mA mA
Input voltages Pin 2, 3 and 5 Pin 6	V_I	V_S 1	V V
Input currents Pins 2, 3 and 5	I_I	1	mA
Output voltage Pin 7 Pin 4	V_7 V_4	13.4 V_S	V V
Output current $t < 100 \mu s$ Pin 7 Pin 4	I_7 I_4	1.5 5	A mA
Power dissipation $T_{amb} = 85^\circ C$ SO 8 : on p.c. board on ceramic on ceramic with silicon grease	P_{tot} P_{tot} P_{tot}	150 250 430	mW mW mW
Junction temperature	T_j	125	$^\circ C$
Ambient temperature range	T_{amb}	-40 to 85	$^\circ C$
Storage temperature range	T_{stg}	-40 to 150	$^\circ C$

Thermal Resistance

Parameters	Symbol	Value	Unit
Junction ambient SO 8: on p.c. board on ceramic on ceramic with silicon grease	R_{thJA} R_{thJA} R_{thJA}	220 140 80	K/W K/W K/W

Electrical Characteristics

$V_S = 6 V$, $T_{amb} = 25^\circ C$, reference point pin 8, unless otherwise specified

Parameters	Test Conditions / Pins	Symbol	Min.	Typ.	Max.	Unit
Supply current						
Pin 1						
Supply voltage	Pin 1	V_S	2.4		12	V
Standby current		I_I			2	μA
Wake-up current	Without pulse	I_I			1.5	mA
Overvoltage protection	$I_I = 20 mA$	V_S		13		V
DATA						
Pin 2						
Input signal	High	V_2	3	3.6	4.2	V
	Low	V_2	1.6	2.1	2.6	V
Common mode input			0		V_S	V
Rise time		t_r			500	ns
Fall time		t_f			500	ns
Signal frequency		f			500	kHz
Input current		I_2			100	μA

Parameters	Test Conditions / Pins	Symbol	Min.	Typ.	Max.	Unit
MON-I Pin 3						
Input current	$V_3 = 6\text{ V}$	I_3			0.3	μA
Reverse current	$V_3 = 0\text{ V}$	I_r			0.8	μA
Input voltage high	MON-I on	V_3	485	525	555	mV
Input voltage low	MON-O off	V_3	515	545	580	mV
Hysteresis				4		%
Temperature coefficient		TC		100		$\mu\text{A/K}$
MON-O Pin 4						
Output current	$V_4 \geq 200\text{ mV}$	I_4	1			mA
Output current	$V_4 \geq 400\text{ mV}$	I_4	3			mA
Reverse current	$V_4 \leq 6\text{ V}$	I_r			0.2	μA
Output voltage High					V_S	V
Saturation voltage	$I_4 = 1\text{ mA}$	V_{sat}			200	mV
WAKE Pin 5						
Input current	$V_5 = 6\text{ V}$	I_5			80	μA
	$V_5 = 0\text{ V}$	I_5			± 0.2	μA
Input voltage High	Busy	V_5			V_S	V
Input voltage LOW	Standby	V_5	0		0.2	V
SHUNT Pin 6						
Output current IRED	$V_S = 2.4\text{ V}; R_S = 0.62\ \Omega$	I_7	205		245	mA
	$V_S = 6.0\text{ V}; R_S = 0.62\ \Omega$	I_7	220		265	mA
	$V_S = 12\text{ V}; R_S = 0.62\ \Omega$	I_7	235		275	mA
	$V_S = 6\text{ V}; R_S = 0.11\ \Omega$	I_7	1.25		1.5	A
	$V_S = 12\text{ V}; R_S = 0.11\ \Omega$	I_7	1.3		1.55	A
Shunt voltage	$V_2 = V_S = 6\text{ V};$ $R_S = 0.11\ \Omega$	V_{Shunt}	140	150	160	mV
Temperature coefficient	$T_{\text{amb}} = -40\text{ to }85^\circ\text{C}$	T_C		40		$\mu\text{V/K}$
IRED Pin 7						
Output voltage	$V_2 = V_S = 6\text{ V}; I_7 = 1\text{ A}$	V_{out}			1000	mV
Output voltage	$V_2 = 0\text{ V}; I_7 = 0$	V_{out}		12	13.2	V
Reverse current	$V_2 = 0\text{ V}; V_7 = 6\text{ V}$	I_r			1	μA
Rise/Fall time		t_r			300	ns
Delay time	Pin 2 to pin 7	t_d			1	μs
Standby/Busy		t_{SB}			1	ms
Busy/Standby		t_{BS}			1	ms

U426B

TEMIC

TELEFUNKEN Semiconductors

Dimensions in mm

Package: SO 8

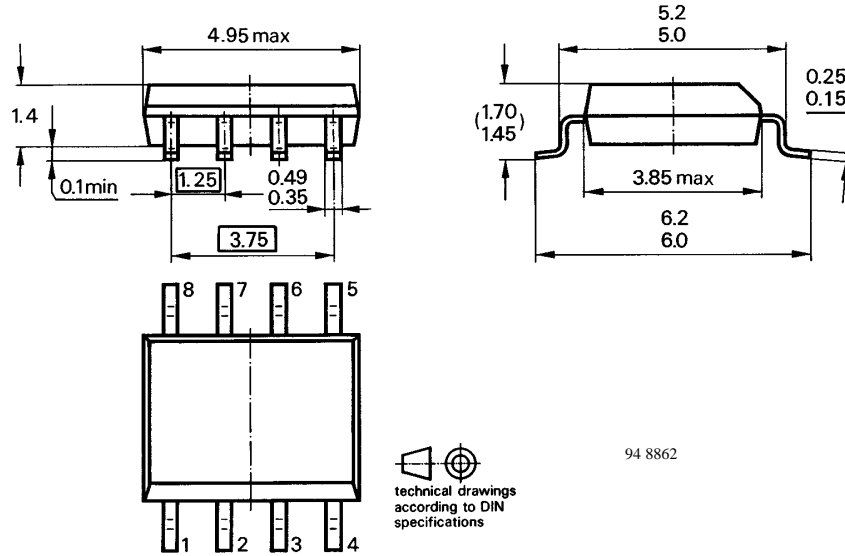

Ozone Depleting Substances Policy Statement

It is the policy of **TEMIC TELEFUNKEN microelectronic GmbH** to

1. Meet all present and future national and international statutory requirements.
2. Regularly and continuously improve the performance of our products, processes, distribution and operating systems with respect to their impact on the health and safety of our employees and the public, as well as their impact on the environment.

It is particular concern to control or eliminate releases of those substances into the atmosphere which are known as ozone depleting substances (ODSs).

The Montreal Protocol (1987) and its London Amendments (1990) intend to severely restrict the use of ODSs and forbid their use within the next ten years. Various national and international initiatives are pressing for an earlier ban on these substances.

TEMIC TELEFUNKEN microelectronic GmbH semiconductor division has been able to use its policy of continuous improvements to eliminate the use of ODSs listed in the following documents.

1. Annex A, B and list of transitional substances of the Montreal Protocol and the London Amendments respectively
2. Class I and II ozone depleting substances in the Clean Air Act Amendments of 1990 by the Environmental Protection Agency (EPA) in the USA
3. Council Decision 88/540/EEC and 91/690/EEC Annex A, B and C (transitional substances) respectively.

TEMIC can certify that our semiconductors are not manufactured with ozone depleting substances and do not contain such substances.

We reserve the right to make changes to improve technical design and may do so without further notice.

Parameters can vary in different applications. All operating parameters must be validated for each customer application by the customer. Should the buyer use TEMIC products for any unintended or unauthorized application, the buyer shall indemnify TEMIC against all claims, costs, damages, and expenses, arising out of, directly or indirectly, any claim of personal damage, injury or death associated with such unintended or unauthorized use.

TEMIC TELEFUNKEN microelectronic GmbH, P.O.B. 3535, D-74025 Heilbronn, Germany
Telephone: 49 (0)7131 67 2831, Fax number: 49 (0)7131 67 2423